

POMPA AIR ORIGINAL ITALY

DAB[®]

WATER • TECHNOLOGY

**ASLI
TANPA
EMBEL-EMBEL**



SAND FILTER



EUROSWIM

SAND FILTER & POMPA KOLAM RENANG

EUROSWIM



FILTRATION SYSTEM IN THE PUBLIC AND PRIVATE POOL, INDUSTRIAL APPLICATIONS



* Suitable also for salt water

High efficiency self-priming centrifugal pumps with built-in large capacity prefilter. Extremely quiet running and great reliability, developed for water circulation and filtration in domestic and residential swimming pools. Suitable also for special applications that call for handling of aggressive liquids, in fish farms, agriculture and industry. Pump body in fibreglass reinforced technopolymer. Strainer cover in clear antioxidant polycarbonate to guarantee constant visibility through time. Nylon strainer. Impeller in fibreglass reinforced technopolymer developed to ensure total coverage and isolation of the motor shaft from the pumped liquid. Diffuser in reinforced technopolymer. Mechanical seal in carbon / alumina / NBR / AISI 316. Pump body O-rings in NBR, threaded fasteners and reinforcing rings in AISI 304. Butterfly drain plugs that can be removed and refitted without tools.

Asynchronous continuous duty 2-pole motor (S1) with generous range of power ratings from 0.5 HP to 3 HP, single phase and three-phase (see technical specifications). Motor casing in die cast aluminium with electrophoretic surface treatment to prevent oxidation even in aggressive environmental conditions. Baseplate supplied as standard with rubber mounts to reduce vibration transmission. Single phase version with integral thermal and overcurrent protection and permanent split capacitor (PSC), assembled inside the terminal box for all versions.

Motor and terminal box protection rating: 1P55

Insulation class: F

Ball bearings:

water-proof, sealed, resistant to water and humidity.

Motor construction to EN 60335-2-41 standards

Standard voltage : Single phase 220-240V 50Hz

Three-phase 230/400V 50Hz

Operating range: up to 42 m³/h with pressure head of up to 22 m

Pumped fluid: clean water or water slightly contaminated with suspended particulate, long fibre; highly aggressive water with high percentage contents of chlorine/bromine and PHMB (Polyhexamethylene Biguanide) or water treated with chlorine electrolytic process.

Liquid temperature range: up to 60°C

Maximum ambient temperature: +50°C

Maximum operating pressure: 2,5 bar

Installation: fixed or portable in horizontal position

Special executions on request: alternative voltages and/or frequencies

Fittings on request: 2"/50 - 63 kit (two fittings + O-ring - see "Accessories")

Reference standard: IEC -60364

- Jangkauan operasi sampai dengan 42 m³ / jam dengan maksimal head 22 meter.
- Motor berjalan atau diam dengan tingkat kebisingan berkurang dari 64 - 67 (LpA)
- Tersedia dengan output dari 0,5 HP sampai 3 HP, dengan motor fase tunggal dan tiga.
- Pra-Filter untuk mengurangi risiko penyumbatan, berkat kapasitas penyaringan yang optimal.
- Kapasitas tinggi Pra-Filter sampai 1,5 HP 4 liter dan sampai 3 HP dari 5 liter.
- Suhu Cair : sampai 60° C
- 2" Hisap dan Debit Port diperkuat dengan Stainless Steel Ring.

INTERNAL FILTER
 Dengan permukaan halus mudah untuk di bersihkan
 Ukuran Filter : bagian kecil dari kisaran : 2,5 liter bagian yang lebih besar dari kisaran : 3,2 liter

MUDAH UNTUK DI BUKA TANPA MENGGUNAKAN ALAT APAPUN DAN MUDAH DI BERSIHKAN

PERMUKAAN FILTER MUDAH DI CUCI DAN DI BERSIHKAN

INTERNAL FILTER
 - PENUTUPAN mudah di buka dan dibersihkan
 - TRANSPARAN memudahkan perawatan
 - DENGAN HANDLE BIG mudah untuk di buka dan di bersihkan tanpa menggunakan alat apapun dan membuat pompa berumur panjang.

EUROSWIM 75

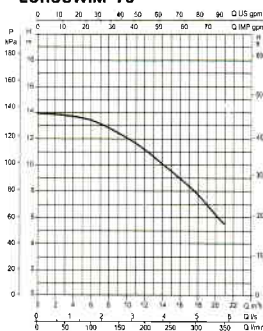

EUROSWIM 100

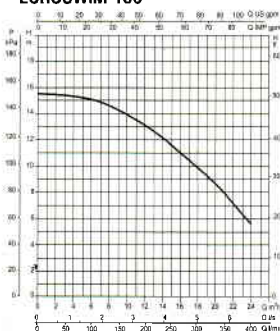

EUROSWIM 150

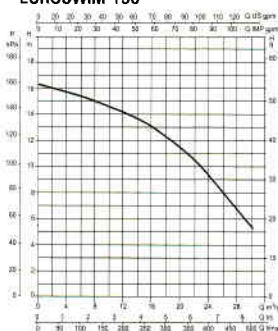

EUROSWIM 200



EUROSWIM 300

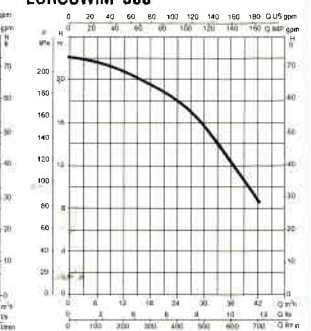

Type	Supply Voltage	P2 Nominal	HP	In	Kapasitor	Max Tingkat kebisingan	Data Kapasitas Pompa												
							Q = m ³ /h												
							Q = liter/menit	0	3	6	9	12	18	21	24	30	36	42	
EUROSWIM 75 M	1 x 220 - 240 v ~	0.5	0.75	5	20	450	65	13,8	13,5	13,1	12,4	11,1	7,5	5					
EUROSWIM 100 M	1 x 220 - 240 v ~	0.75	1.00	6.3	25	450	66	15,4	15,4	15,0	14,2	13,1	10,1	7,8	5,6				
EUROSWIM 150 M	1 x 220 - 240 v ~	1.1	1.50	7	31.5	450	66	16,2	15,9	15,4	14,9	14,2	12,4	11,1	9,3	5,3			
EUROSWIM 200 M	1 x 220 - 240 v ~	1.5	2.00	8.8	40	450	67	18,6	18,2	17,7	17,1	16,5	15,0	14,1	12,8	9,0	4,0		
EUROSWIM 300 M	1 x 220 - 240 v ~	2.2	3.00	12	40	450	64	22,0	21,9	21,7	21,3	20,8	19,6	18,9	18,1	15,9	12,5	8,6	
EUROSWIM 300 T	3 x 230 - 400 v ~	2.2	3.00	8,7/5	-	-	64	22,0	21,9	21,7	21,3	20,8	19,6	18,9	18,1	15,9	12,5	8,6	

E.SWIM - VARIABEL SPEED



PENYARING KOTORAN

FILTER

Filter mudah di bersihkan di buka



POSISI DUDUKAN POMPA

ANTI GETAR

Pemasangan sangat mudah dan anti getar



SISTEM KONTROL

PANEL KONTROL

Layar LCD resolusi tinggi mudah di gunakan



SISTEM

PENDINGIN AIR

Motor pompa mempunyai sistem pendingin yang di dinginkan oleh air



MODEL POMPA

DISAIND

Dengan disain yang kokoh dan sempurna



PART

IMPELLER

Mempunyai konsep impeller dan nozzle untuk meningkatkan kapasitas pompa

TECHNICAL DATA

P1 Max
1250 W

Q Max
30 m³/h

H Max
16 m

Dimensions (mm)
550x300x316



ELEKTRONIK

VARIABEL SPEED

Dengan sistem variabel speed

MATERIALS

N.	PARTS*	MATERIALS
1	PUMP BODY	REINFORCED TECHNOPLYMER
4	IMPEIER	REINFORCED TECHNOPLYMER
6	VOLUTE	REINFORCED TECHNOPLYMER
8	STRAINER COVER	POLYCARBONATE
10	STRAINER	TECHNOPOLYMER
16	MECHANICAL SEAL	CARBON/A WMINAJNB WAISI/31 6
28	O-RING	NBR
29	O-RING	NBR
36	SEAL HOLDING DISC	EPD

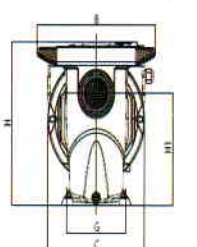
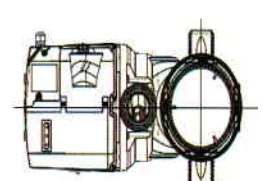
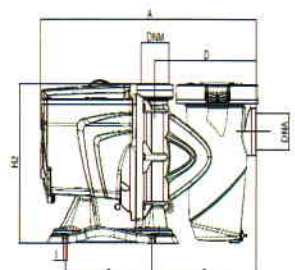
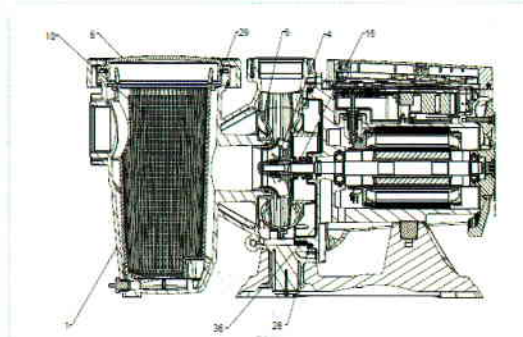

MODEL	U.S. Gpm	Q	26.4	52.8	79.3	92.5	105.7	118.9	132
E.SWIM 150 M	ft (H2O)	50.5	47.6	45.6	38.4	35.1	31.7	28.4	23.0

MODEL	POWER INPUT 50/60 Hz	P1 MAX W	P2 NOMINAL		In A	NOISE LEVEL MAX db (A)
			KW	HP		
E.SWIM 150 M	230 V	1250	1.1	1.5	5.6	< 50 db(A)

MODEL	A	B	C	D	E	F	G	H	H1	H2	I	DNA / DNM NPT	PACKING DIMENSIONS (in)			GROSS WEIGHT lb
	in	in	in	in	in	in	in	in	in	in	in	L/A	L/B	H		
E.SWIM 150 M	21.7	11.8	9.6	10.2	10.5	8.7	5.9	12.4	8.5	12.2	0.4	2"	28.3	13.8	16.9	41.9

SAND FILTER



- Bahan material fiberglass yang berkualitas tinggi.
- Tekanan kerja maksimum : 250 kPa/36psi
- Tekanan pengujian pabrik : 400 kPa/58psi
- Suhu air maksimal : 43°C (109°F)
- Maks. Kecepatan Filter : 50m³ / h / m
- Ukuran pasir silika : 0,5 - 0,8mm

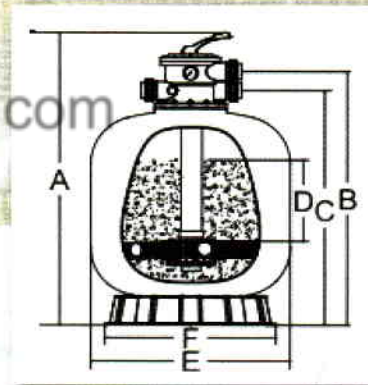
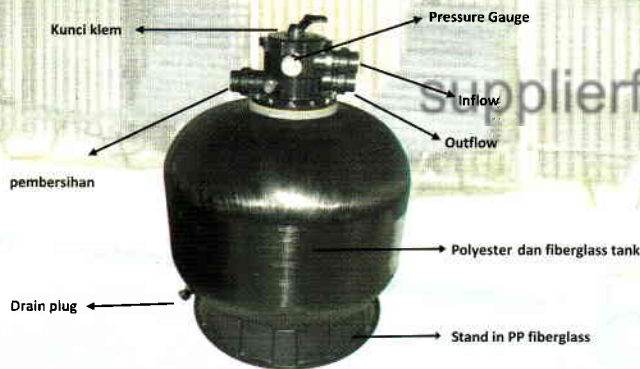

Model No	Filter Area (m ²)	Valve Connections		Max Flow Rate		Sand (kg)
V500	0.22	1.5 inch	50mm	1851pm	11.10m ³ /h	85
V700B	0.41	2.0 inch	63mm	3361pm	20.16m ³ /h	215
V800	0.50	2.0 inch	63mm	4151pm	24.90m ³ /h	355
V900	0.54	2.0 inch	63mm	5201pm	31.20m ³ /h	470

Model No	A mm	B mm	C mm	D mm	E mm	F mm
V500	845	730	670	235	535	500
V700B	1092	960	877	390	723	500
V800	1200	1085	1002	425	800	753
V900	1300	1172	1090	480	900	753